



AMENDED NOTICE OF BUDGET & FINANCE COMMITTEE MEETING

NOTICE IS HEREBY GIVEN that the San Lorenzo Valley Water District has called a regular meeting of the Budget & Finance Committee to be held Tuesday, **September 6, 2016 at 9:30 a.m.** at the Operations Building, 13057 Highway 9, Boulder Creek, California.

AGENDA

1. Convene Meeting/Roll Call
2. Oral Communications
This portion of the agenda is reserved for Oral Communications by the public for items which are not on the Agenda. Please understand that California law (The Brown Act) limits what the Board can do regarding issues raised during Oral Communication. No action or discussion may occur on issues outside of those already listed on today's agenda. Any person may address the Committee at this time, on any subject that lies within the jurisdiction of the District. Normally, presentations must not exceed three (3) minutes in length, and individuals may only speak once during Oral Communications. Any Director may request that the matter be placed on a future agenda or staff may be directed to provide a brief response.
3. Old Business: None
Members of the public will be given the opportunity to address each scheduled item prior to Committee action. The Chairperson of the Committee may establish a time limit for members of the public to address the Committee on agenda items.
4. New Business:
Members of the public will be given the opportunity to address each scheduled item prior to Committee action. The Chairperson of the Committee may establish a time limit for members of the public to address the Committee on agenda items.
 - a. DRAFT CAPITAL COST-OF-SERVICE STUDY REPORT
Discussion and possible action by the Committee regarding the draft Capital Cost-of-Service Study report.
5. Informational Material: None.
6. Adjournment

In compliance with the requirements of Title II of the American Disabilities Act of 1990, the San Lorenzo Valley Water District requires that any person in need of any type of special equipment, assistance or accommodation(s) in order to communicate

at the District's Public Meeting can contact the District Office at (831) 338-2153 a minimum of 72 hours prior to the scheduled meeting.

Agenda documents, including materials related to an item on this agenda submitted to the Committee after distribution of the agenda packet, are available for public inspection and may be reviewed at the office of the District Secretary, 13060 Highway 9, Boulder Creek, CA 95006 during normal business hours. Such documents may also be available on the District website at www.slvwd.com subject to staff's ability to post the documents before the meeting.

Certification of Posting

I hereby certify that on September 2, 2016, I posted a copy of the foregoing agenda in the outside display case at the District Office, 13060 Highway 9, Boulder Creek, California, said time being at least 72 hours in advance of the regular meeting of the Budget & Finance Committee of the San Lorenzo Valley Water District in compliance with California Government Code Section 54956.

Executed at Boulder Creek, California, on September 2, 2016.

Holly B. Morrison, District Secretary
San Lorenzo Valley Water District



COST OF SERVICE STUDY – CAPITAL PROJECT NEEDS ASSESSMENT



San Lorenzo Valley Water District
August 2016

Prepared by



V.W. HOUSEN
& ASSOCIATES

This page left intentionally blank

Table of Contents

| | |
|---|----|
| EXECUTIVE SUMMARY | 1 |
| ES-1 WATER AND WASTEWATER ASSETS | 2 |
| ES-2 ASSET VALUATION..... | 3 |
| ES-3 FINDINGS AND RECOMMENDATIONS..... | 4 |
| ES-4 CONCLUDING REMARKS..... | 4 |
| 1.0 INTRODUCTION | 1 |
| 2.0 PURPOSE..... | 2 |
| 3.0 BACKGROUND INFORMATION | 2 |
| 4.0 WATER AND WASTEWATER SYSTEM DESCRIPTIONS..... | 3 |
| 4.1 Individual Water Systems | 4 |
| 4.2 Groundwater Supply | 7 |
| 4.3 Surface Water Supply | 8 |
| 4.4 Distribution System Assets | 10 |
| 4.5 Wastewater System Assets..... | 13 |
| 5.0 SUMMARY OF FINDINGS | 15 |
| 5.1 Surface Water..... | 15 |
| 5.2 Treated Water Storage | 17 |
| 5.3 Water Distribution Facilities..... | 18 |
| 5.3.1 Booster Pump Stations..... | 18 |
| 5.3.2 Linear Assets..... | 18 |
| 5.4 Groundwater Facilities..... | 19 |
| 5.5 Wastewater Facilities | 19 |
| 5.6 Lompico Water System..... | 20 |
| 6.0 RECOMMENDATIONS FOR DEVELOPMENT..... | 20 |
| 6.1 Review of Current CIP..... | 20 |
| 6.2 Conceptual Long-Term Asset Valuation | 22 |

This page left intentionally blank

EXECUTIVE SUMMARY

The San Lorenzo Valley Water District (District or SLVWD) serves the communities of Boulder Creek, Brookdale, Ben Lomond, Felton and portions of Scotts Valley in Santa Cruz County. Figure ES-1 provides a map developed by the Local Agency Formation Commission (LAFCO) showing the District’s service area.

In August 2016, V. W. Housen & Associates (VWHA), as a subconsultant to NBS Financial Services, completed the capital asset replacement component of the District’s Cost of Service Study. The capital asset replacement component documents existing water supply, treatment, storage, and distribution assets to the extent possible, given the limited data available; reviews the effectiveness of SLVWD’s current Capital Improvement Program (CIP) in reference to the goals established in the 2015 Strategic Plan; provides a concept level valuation of the District’s capital assets; presents findings regarding the general condition of these assets; and provides recommendations for future evaluations needed to further review the cost of service.

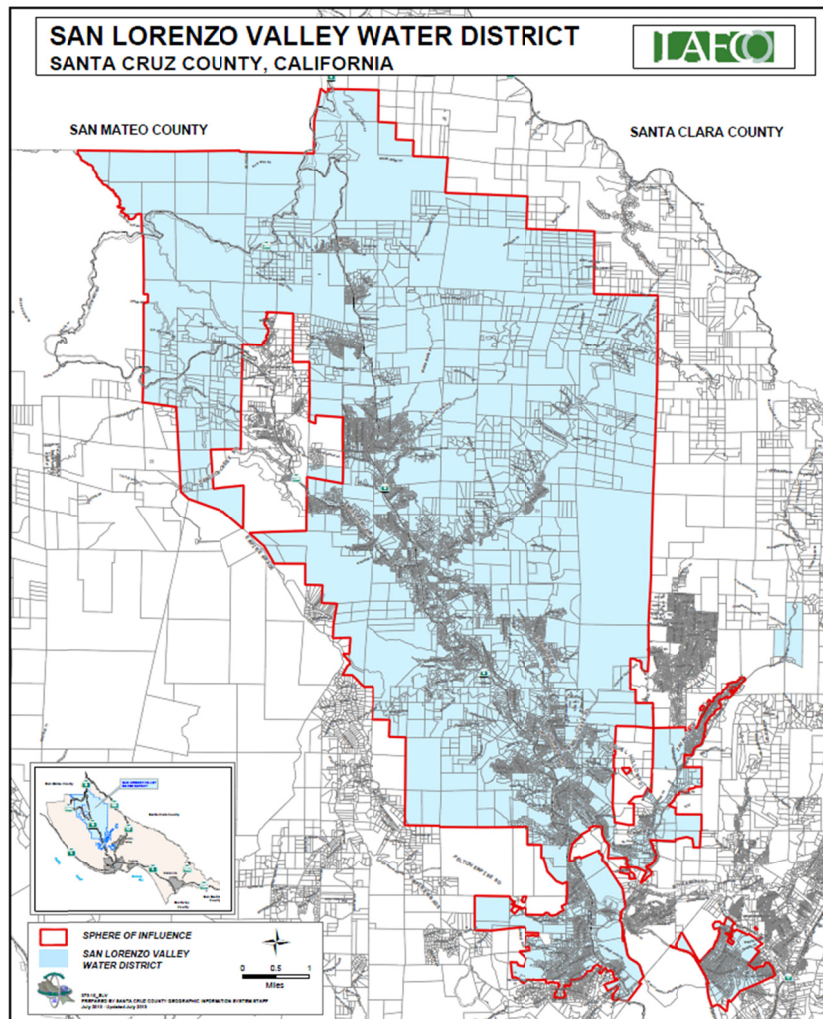

Figure ES-1. San Lorenzo Valley Water Service Area

Aging infrastructure is the District’s primary concern when establishing and prioritizing capital project needs. The age and condition of existing infrastructure are further influenced by factors such as topography, isolation of some communities, and challenging vehicular access throughout the service area. Most of the distribution mains and associated water infrastructure were installed during or prior to the 1950s. Therefore, the mean age of linear assets is approximately 65 years old. The oldest facilities in the service area have reached the end of their expected service life. A large portion of the system will approach the end of its service life in the next two decades.

ES-1 WATER AND WASTEWATER ASSETS

SLVWD serves a population of approximately 20,000 through 7,800 service connections. The District’s average water production is 2.0 million gallons per day (mgd). Residential water use accounts for 85 percent of customer deliveries.

SLVWD has two sources of supply: local groundwater and local surface water. SLVWD owns, operates and maintains four distinct water systems referred to as North, South, Felton and Mañana Woods Systems.

SLVWD’s distribution system, also summarized in Table ES-1, consists of 32 pressure zones, 144 miles of pipeline, 35 treated water tanks and reservoirs, and 31 booster pump stations. The District operates and maintains the Lyon Water Treatment Plant (1,200 gallons per minute or gpm) and the Kirby Water Treatment Plant (350 gpm). The Lyon Water Treatment Plant serves the North System and the Kirby Water Treatment Plant serves the Felton System.

Table ES-1. System Assets

| Summary Of System Assets |
|---|
| 144 miles of pipeline, ranging from 2- to 14-inches in diameter |
| 35 water storage tanks and reservoirs |
| 2 drinking water treatment plants |
| 32 pressure zones and 31 pump stations |
| 10 active surface water diversions |
| 10 groundwater wells |
| 3 operations/administration buildings |

Local groundwater is supplied by seven wells located in three different well fields that access a single primary aquifer (Lompico Sandstone) and a secondary aquifer (Santa Margarita Sandstone). Average production is approximately 1,000 acre-feet per year, which supplies 40 to 60 percent of SLVWD’s water demands.

SLVWD’s surface water is supplied by intakes on small streams that are primarily available during the winter and spring months and are directly dependent upon local precipitation. Typically, surface water

diversions account for approximately half of SLVWD's supply. However, in above-average rainfall years, surface water diversions can potentially address 100 percent of demand. When the seasonal nature of area rainfall and limited surface water storage require supplemental supplies, groundwater is used to augment supply (typically during fall and early winter months).

SLVWD's distribution system pipeline diameters range from 2-inch to 14-inch. Over half the pipelines are 4 inches in diameter or less. Water pressure issues have been reported, and water supply availability for fireflow can be challenging in many areas.

In June 2016, the District annexed the Lompico water system. The system serves 500 connections in the Lompico Creek canyon area. Existing infrastructure consists of six redwood tanks, two water treatment plants, four wells, one pump station, nine pressure-reducing valves, and three miles of water mains.

The District also provides wastewater collection and treatment for 56 parcels, which comprise approximately half of the parcels within the Bear Creek Estates subdivision. The wastewater collection system and a septic disposal system were constructed in 1985. Subsequently, in 2005, the septic system was converted to enable nitrogen removal as required by the Regional Water Quality Control Board.

ES-2 ASSET VALUATION

A conceptual valuation of the District's assets, using available information and assigning representative costs for each asset class, is \$145 million. The valuation per asset class is shown in Table ES-2.

Table ES-2. ASSET VALUATION BY CLASS

| Asset Class | Amount | Unit | Unit Price | Facility Value | Design Life (Years) |
|---------------------|-----------|-------------|-------------|----------------------|---------------------|
| Pipelines | 760,320 | Linear foot | \$70 | \$53,222,400 | 70-100 |
| Tanks | 9,240,000 | Gallon | \$3 | \$27,720,000 | 50-70 |
| Pump Stations | 31 | Each | \$1,000,000 | \$31,000,000 | 20-30 |
| Wells | 10 | Each | \$1,500,000 | \$15,000,000 | 20 |
| Treatment Plants | 2,360,480 | Gallon | \$2.50 | \$5,901,200 | 25 |
| Diversions | 10 | Each | \$375,000 | \$3,750,000 | 50 |
| Ops/Admin Bldgs | 3 | Square-foot | \$112.44 | \$8,147,604 | 60 |
| Total Assets | | | | \$144,741,204 | |

Due to the limit amount of information that was available on asset age, condition, and replacement schedule, the current valuation relied upon numerous assumptions and general rules of thumb for asset life, asset costs, and replacement schedules. These values should be refined through more detailed

planning studies that are recommended for completion during the first three years of the capital improvement program.

ES-3 FINDINGS AND RECOMMENDATIONS

Table ES-3 on the following page presents findings regarding the capital replacement component of the District's Cost of Service study. These findings are discussed in further detail within this report. Table ES-3 references the applicable section of the report for each of the findings.

ES-4 CONCLUDING REMARKS

VWHA has developed a preliminary valuation for the District capital assets, and has assigned general replacement timelines for each asset class. The replacement schedule is conceptual in nature, and was developed to provide information to inform the District's Cost of Service study.

Based on this initial valuation and replacement schedule, future average annual budgeting of \$2.5 to 3.5 million in current dollars for next 30 years would allow SLVWD to complete necessary replacements while reducing risk. Beyond this timeframe, average annual spending is projected to decrease by approximately half. This initial valuation and schedule were developed using limited information regarding existing asset age and condition. The projections should be refined further, as additional asset and operations/maintenance data are compiled and recorded.

VWHA has also established an interim capital replacement plan using the District's current CIP as a basis. During the first three years of this interim plan, it is recommended that the District conduct more detailed facility master planning in order to more accurately identify, estimate costs, and prioritize future capital replacement needs. The most important activity to undertake in the next three years is the implementation of an asset management approach for pipelines, storage, and pumping plant asset rehabilitation and replacement.

TABLE ES-3. FINDINGS AND RECOMMENDATIONS

| Findings, Including Reference Section | Recommendation |
|---|--|
| The current Water Treatment System requires a comprehensive planning document that outlines all of the aspects of the system and potential costs of improving the system. (Pg. 10) | Develop a Treatment Master Plan for the two Water Treatment Plants and the Wastewater Treatment Plant to provide documentation of the current facilities, conditions, compliance documentation, potential maintenance costs, potential capital replacement projects and associated costs. |
| Above-ground pipelines are prone to vandalism and other issues that could damage their structural integrity. (Pg. 10-11) | Perform a physical assessment of each intake as well as a physical inventory of visible pipelines. |
| San Lorenzo Valley Water District is planning to integrate the Loch Lomond supply into its system. (Pg 11-13) | Update the scope and cost estimates for the Loch Lomond Reservoir Source Development Study and seek grant funding for a joint project with Scotts Valley WD. Also, evaluate the effectiveness of the Mill Creek surface water diversion and review alternatives. |
| Currently, the SLVWD has a lack of surface water storage. Water is pumped, diverted, and treated according to immediate demands. Also, storage tanks require inspection to determine if they are at risk of failure. (Pg. 13) | Review tank inspection reports and evaluate the condition of exterior coatings, interior liners, and roofs to assess each tank's condition. Determine the highest-priority replacement candidates, as well as establish storage volume criteria for each system and zone. |
| The District should complete assessments for the 28 booster pump stations to help identify deficiencies and determine the current state of each facility. Assessments should include mechanical equipment, structural issues, ventilation, entrance/security, safety issues, electrical, and communication systems. (Pg. 13-14) | Perform a physical assessment of booster pump stations by system to identify and prioritize necessary repairs/replacements. |
| SLVWD owns and maintains approximately 144 miles of distribution pipeline. Due to issues presented by terrain, topography, and isolated communities, the system should be assessed and projects prioritized based on risk. For example, landslide risk and having sufficient fire flow are of concern (Pg. 14-15) | Develop a risk-based Linear Asset Management Plan that includes collecting and reviewing asset data, including O&M data, and integrating this information into a GIS database. Use this information to prioritize new pipeline replacements. Consider stockpiling spare pipeline materials in case of emergency. |
| SLVWD recently annexed the Lompico County Water District and its aging infrastructure. Challenging topography, the remote location, and narrow roadways will likely increase the costs of improving the infrastructure. (Pg. 15-16) | Perform system inspections to identify potential infrastructure upgrades that may include tank consolidation, wellhead repair, service lateral replacement, SCADA and automation system implements, and pump station installations. |
| Scotts Valley Water District and San Lorenzo Valley Water District share the same groundwater basin; this knowledge must be considered when managing groundwater use. Continued groundwater overdraft is a risk if the two agencies do not work together to manage use. SLVWD's operations have a major influence on the regional groundwater table and may directly impact SLVWD's ability to pump from the aquifer. (Pg. 16-17) | Continue evaluation of options for groundwater recharge/replenishment through additional use of surface water diversions or a long-term project. This issue is critical due to the long-term drop in water levels in the Pasatiempo Wellfield and the continued use of the basin by Scotts Valley WD. In addition, establish a database of private wells in the groundwater basin to begin GW management activities. |
| The District conducted an assessment of the Bear Creek Estates wastewater collection and treatment system in response to recent action by the Central Coast RWQCB. (Pg. 17) | Implement initial improvements recommended by the District's consultant, IEC, that include: complete smoke testing of remaining property, install manhole inserts, epoxy seal manholes, replace 195 LF of sewer pipeline. Also, develop a Sanitary Sewer Management Plan for the Bear Creek Treatment System. |

This page left intentionally blank

CAPITAL ASSET SUMMARY AND VALUATION

1.0 INTRODUCTION

San Lorenzo Valley Water District (SLVWD or District) was established in 1941 in the mountains of Santa Cruz County. The District serves the communities of Boulder Creek, Brookdale, Ben Lomond, portions of Felton, portions of the City of Scotts Valley and surrounding unincorporated areas, and provides a combination of water and wastewater services to all or parts of its service area. SLVWD serves a population of approximately 20,000 through 7,800 service connections. Figure 1 shows the District’s service area, as provided by the Local Area Formation Committee (LAFCO) in their document titled, “San Lorenzo Valley Water District.”

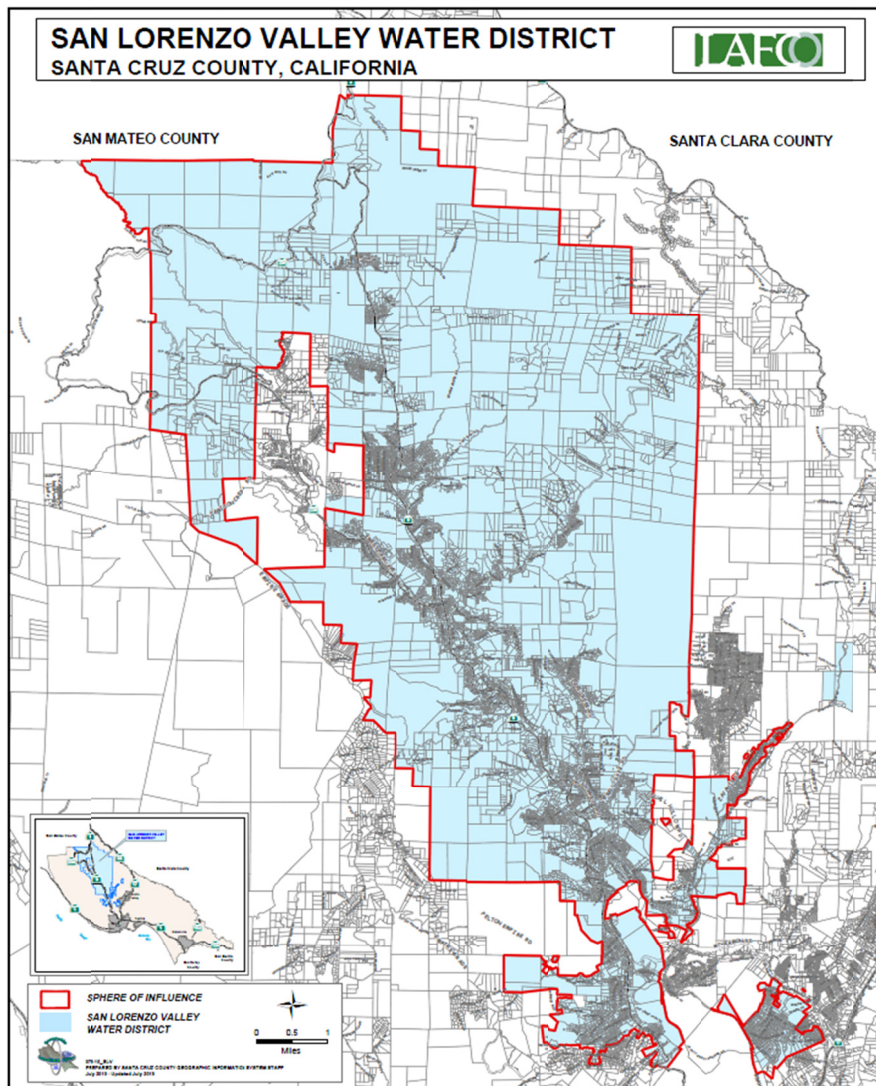

Figure 1 – San Lorenzo Valley Water Service Area

In 2015, SLVWD authorized a contract with NBS Consultants to complete a cost of service study for its domestic water services. NBS subcontracted with V. W. Housen & Associates, Inc. (VWHA), to

complete an assessment of the District's current capital needs and priorities, in support of this effort. Separate analyses were completed by others related to staffing and policies. This report summarizes the work completed by VWHA for the capital needs assessment.

This Technical Memorandum is organized as follows:

1. Introduction
2. Purpose
3. Background Information
4. Water and Wastewater System Descriptions
5. Summary of Findings
6. Recommendation for update of District's CIP

2.0 PURPOSE

The purpose of the CIP assessment is to document SLVWD's existing water supply, treatment, storage and distribution assets; evaluate the CIP's efficacy as it relates to goals established by the SLVWD in the 2015 Strategic Plan for capital improvements and reliability; determine the CIP's effectiveness as a tool for managing the SLVWD's infrastructure; and provide recommendations on how to improve the CIP planning process. This evaluation included an initial program to identify, evaluate, and prioritize the District's current and future capital needs.

3.0 BACKGROUND INFORMATION

The CIP assessment approach included compilation and review of a range of source material, and evaluation of this background material in the context of the 2015 Strategic Plan goals

The compilation of background information for the capital program assessment began with knowledge transfer through a full-day field tour of existing facilities and associated discussions with the District's operation, maintenance, and management staff to understand facility and system needs. Additional research and review of publicly available District documents followed this field tour. Documents reviewed included financial background, planning and engineering documents, various agreements, and reports, meeting notes, and other documentation related to water and wastewater service and infrastructure. These documents are summarized below.

Financial information reviewed by the project team included the following:

- 2010 10-year Capital Improvement Plan (CIP)
- 2015/16 adopted budget (including the 1 year CIP)
- 2015 Final CIP Project List
- September 2015 Draft 2015 CIP Work Plan Board Presentation

Planning and Engineering documents reviewed included:

- SLVWD 2015 Strategic Plan
- 2009 Water Supply Master Plan
- 2015 Urban Water Management Plan
- SLVWD Initial Study/Mitigated Negative Declaration for the Interties Project

- San Lorenzo Valley and North Coast Watersheds Sanitary Survey
- Loch Lomond Reservoir Source Development Study
- Lompico Final Engineer’s Report
- Pro Forma Budget for Lompico Water System Merger
- Executive Officer’s Report for the Lompico Merger
- California Department of Public Health Enforcement Action letters for the Lompico System.

The source material listed above was reviewed against the adopted 2015 CIP, the Final CIP Project List (2015), and the adopted 2015 Strategic Plan to evaluate whether the District’s planned capital spending is aligned with its strategic goals.

4.0 WATER AND WASTEWATER SYSTEM DESCRIPTIONS

SLVWD owns, operates and maintains four distinct water systems referred to as North, South, Felton and Mañana Woods Systems. The District’s current daily average water production is 2.0 million gallons per day (mgd). Residential water use accounts for 85% of customer deliveries, from two sources of supply: local groundwater and local surface water.

The District’s distribution system consists of 32 pressure zones, 144 miles of pipeline, 35 treated water tanks and reservoirs, and 31 booster pump stations. These assets are summarized in Table 1 below. The District operates and maintains the Lyon Water Treatment Plant (1,200 gallons per minute (gpm)) and the Kirby Water Treatment Plant (350 gpm) for the treatment of surface and groundwater supplies. The Lyon Water Treatment Plant serves the North System and the Kirby Water Treatment Plant serves the Felton System. According to the District’s Urban Water Management Plan (UWMP), the annual water production from all sources is approximately 14 percent greater than metered water deliveries.

| Table 1. Summary Of System Assets (Excluding Lompico) |
|---|
| 144 miles of pipeline, ranging from 2- to 14-inches in diameter |
| 35 water storage tanks and reservoirs |
| 2 drinking water treatment plants |
| 32 pressure zones and 31 pump stations |
| 10 active surface water diversions |
| 10 groundwater wells |
| 3 operations/administration buildings |

SLVWD has grown over time, as the result of acquisition of or consolidation with neighboring water purveyors. Most recently, the Lompico community’s water system was annexed by SLVWD. Prior to this annexation, the town of Felton was consolidated into the distribution system in 2008, and the community of Mañana Woods was consolidated into the South Service area in 2006. This history has led to District’s current configuration of multiple, substantially independent water systems rather than a single

consolidated system. The System Diagram included as Figure 2 shows the District's individual water systems and the locations of the two water treatment plants.

4.1 Individual Water Systems

Seven surface water intakes and two well fields provide supply to the North System's Lyon Water Treatment Plant (WTP). The Lyon WTP is a two-stage package filtration plant that uses floating media to remove floc particles followed by granular media filtration and chemical disinfection. The plant has two TM-350 Tri-Mite® Package Plant treatment units rated at 350 gpm or 0.5 mgd, and a plant capacity of 1,150 gpm.

The South System includes groundwater from two wells in the Pasatiempo Wellfield. The wells draw from the Lompico Sandstone and produce between 155 and 255 acre-feet per year (Master Plan). Rainfall on exposed Santa Margarita Sandstone recharges groundwater tapped by the Pasatiempo wells.

Four surface water intakes provide supply to the Felton System's Kirby WTP. The Kirby WTP supplies 1.3 million gallons of water per day to the Felton system.

The Mañana Woods Area is located near the Camp Evers neighborhood of Scotts Valley. The Mañana Woods system was annexed by the District in 2006 and is served by a single well in the Mañana Woods wellfield off Kings Village Road

The individual water systems are joined for reliability through a number of pipeline interties. The attached System Diagram shows the current interties, which are described further below.

The North System and Felton System are connected by a single 8-inch pipeline connection which provides limited hydraulic connectivity, yet additional supply reliability to the Felton System. It should be noted that water from the Felton Water System has a limited place-of-use, according to the Urban Water Management Plan, which does not allow beneficial use outside the town of Felton. "Place-of-use" is established by the State in Felton's water right permit and limits the area where water can be distributed. In this context, the place-of-use is within the Felton town limits. Changing the place of use would require action by the State Water Resources Control Board.

A recently-completed pipeline project connects the South System to the Felton System to provide supply reliability to the South System. This connection is particularly important to the long term viability of the Pasatiempo wellfield. The Pasatiempo wellfield water level has dropped approximately 60 feet over the past 30 years. The connection to the Felton System could allow some groundwater recharge during both average and above average rainfall years, as Felton can now supply local surface water into the South System in lieu of groundwater supplies.

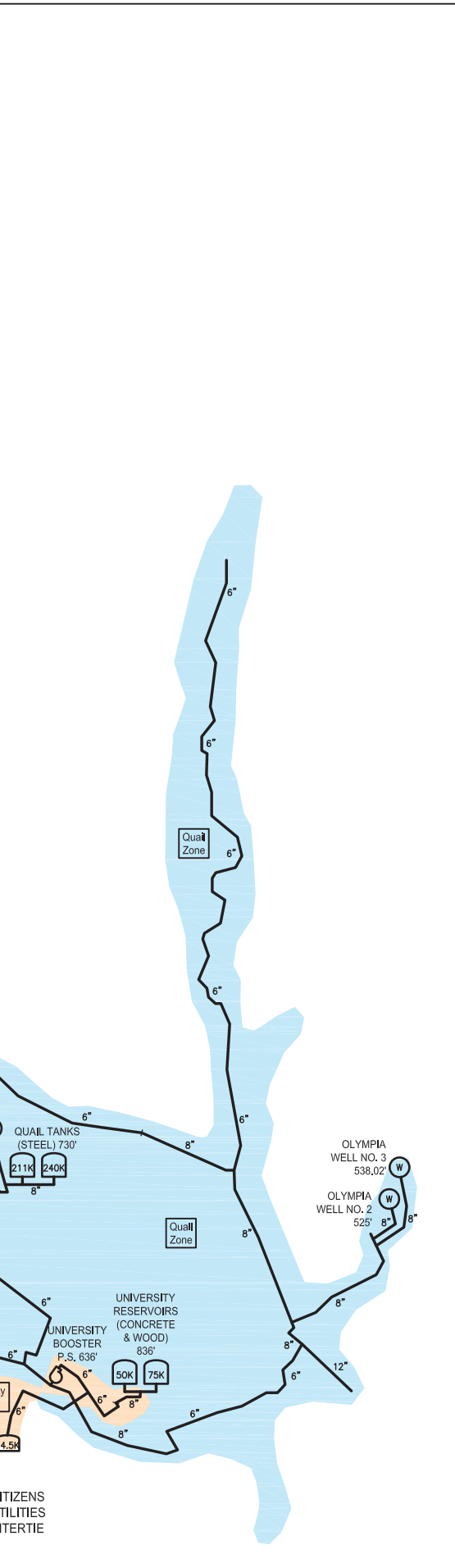
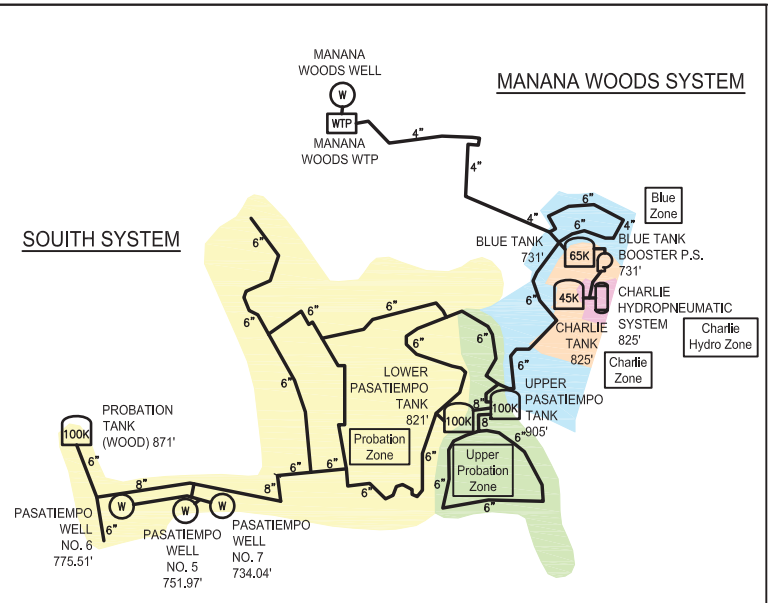
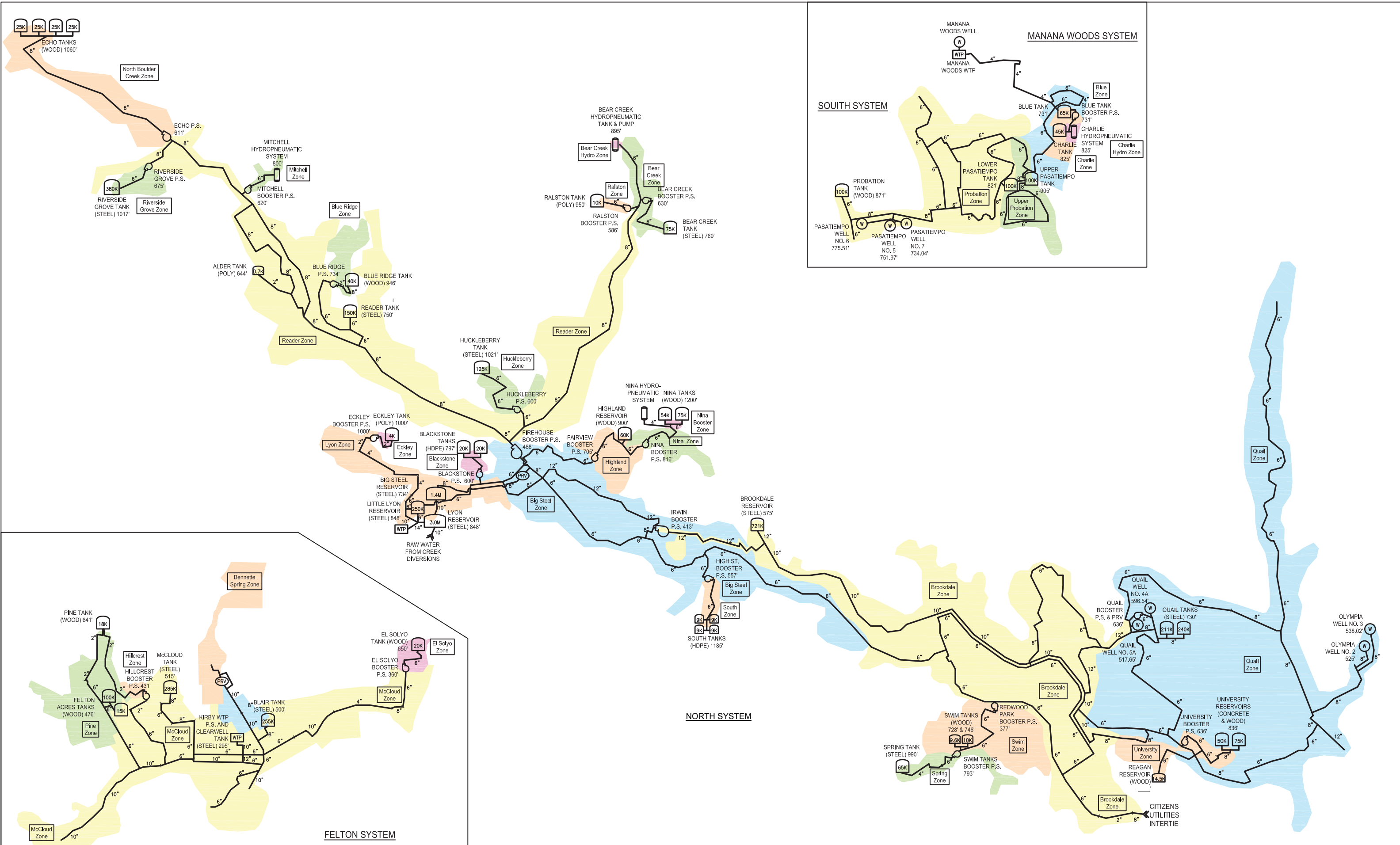

Figure 2
SAN LORENZO VALLEY WATER DISTRICT
DISTRIBUTION SYSTEM ELEVATION DIAGRAM



C:\Users\jg\Documents\San Lorenzo Valley Water District\San Lorenzo Valley Water District Distribution System Elevation Diagram.dwg, 11/15/2011 10:13:24 AM, 11/15/2011

This page left intentionally blank

The South System is also connected to the Mañana Woods System. This system has one 6-inch intertie. Both systems draw water from the same aquifer, and each has a dedicated well field. The intertie serves to improve redundancy if one of the wells needs to be taken off-line for maintenance. Due to the restrictions in place of use for the Felton System's surface water flows and the limited interties between different parts of the service area, SLVWD's customers may experience different levels of water shortage and consequent water use restrictions, voluntary or otherwise, even with these interties in place.

4.2 Groundwater Supply

SLVWD supplies groundwater through seven wells located in three different well fields. The majority of the wells access a single primary aquifer (Lompico Sandstone), and two wells access a second aquifer (Santa Margarita Sandstone). Total average production is approximately 1,000 acre-feet per year. Groundwater typically supplies 40 to 60 percent of the District's water demands. The recent acquisition of the Lompico Water System adds three wells to the District's inventory. However, none of the Lompico wells are currently in service due to water quality issues and required maintenance. Table 2 lists the District's active wells.

Table 2. SLVWD Wells

| Service Area | Well Name | Max Capacity (gpm) |
|--------------|-----------------|--------------------|
| North | Quail Hollow 4A | 360 |
| | Quail Hollow 5A | 185 |
| | Olympia 2 | 495 |
| | Olympia 3 | 430 |
| South | Pasatiempo 6 | 285 |
| | Pasatiempo 7 | 280 |
| | Mañana Woods 2 | 60 |
| Lompico | Well 01 | 4 |
| | Well 05 | 18 |
| | Well 7A | 28 |

Over the past several decades, withdrawals from the Lompico Sandstone formation have exceeded natural recharge. As a result, a cone of depression has formed and water levels have fallen approximately 60 feet at the Pasatiempo Wellfield site. Figure 3 shows this cone of depression. Recommendations to help alleviate this condition are discussed in Section 4.1.8.

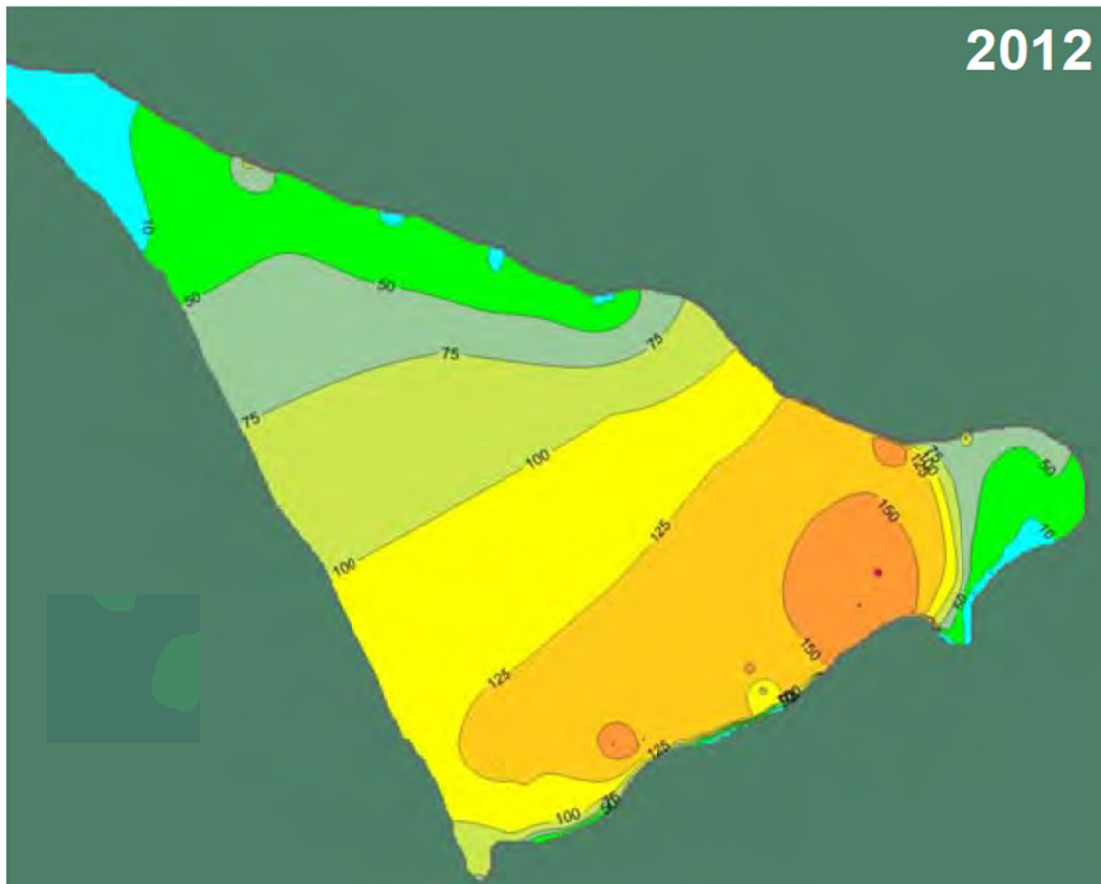

Figure 3. 2012 Groundwater Cone of Depression (Plan View).

In addition to the publicly-managed groundwater supplies, numerous private water wells in the service area and surrounding lands draw from the Lompico Sandstone formation. The County of Santa Cruz has information on the initial construction of private wells including location and depth of these wells. SLVWD is actively participating with Scotts Valley Water District and County of Santa Cruz to develop a Groundwater Sustainability Agency, with the authority to better manage this private well use within the groundwater basin.

4.3 Surface Water Supply

SLVWD's surface water source is supplied through a series of intakes in small surface water streams that are primarily available during the winter and spring. The amount of surface water available for diversion is dependent on local precipitation. SLVWD has pre-1914 surface water rights for its active diversions on Peavine, Silver, Foreman, Clear, Sweetwater Creeks. Figures 4 and 5 show the North System and Felton stream diversions respectively.

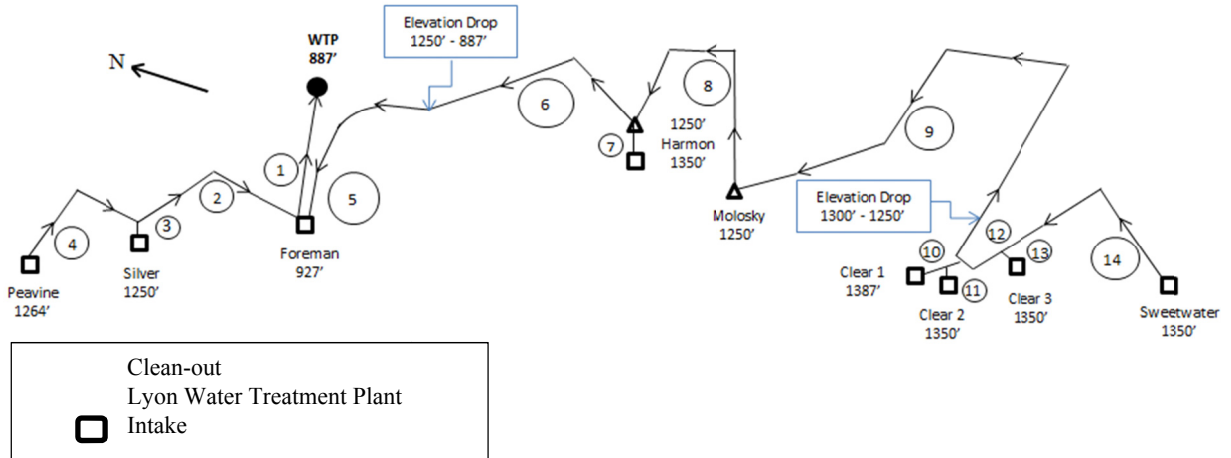

Figure 4. SLVWD North System Schematic Pipeline Layout

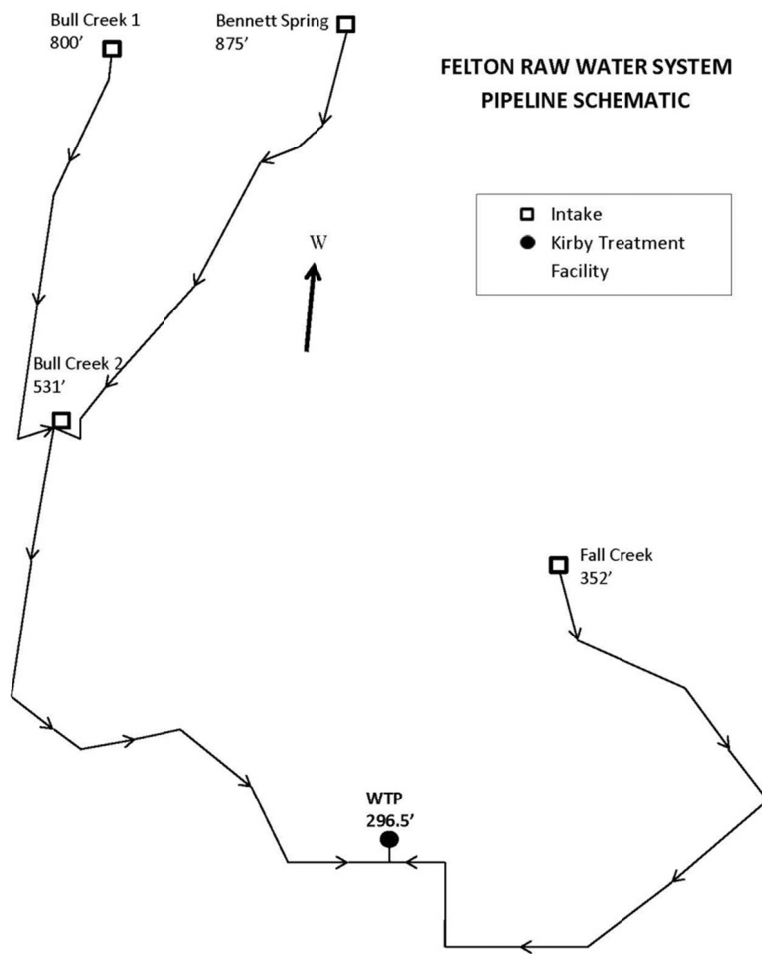

Figure 5. SLVWD Felton System Schematic Pipeline Layout

Table 3 lists the various intakes, elevations, status, and affiliated water system. In addition to the intake locations shown, SLVWD has pre-1914 surface water rights on inactive diversions on Harmon, Earl, and Manson Creeks.

Table 3. District's Water Intake Locations

| Intake | Elevation (Feet) | Status | System |
|----------------|------------------|--------------------------|--------|
| Peavine | 1264 | Active | North |
| Silver | 1250 | Active | North |
| Foreman | 927 | Active | North |
| Harmon | 1350 | Inactive | North |
| Malosky | 1250 | Inactive – no facilities | North |
| Clear 1 | 1387 | Active | North |
| Clear 2 | 1350 | Active | North |
| Clear 3 | 1350 | Active | North |
| Sweetwater | 1350 | Active | North |
| Fall Creek | 352 | Active | Felton |
| Bennett Spring | 875 | Active | Felton |
| Bull Creek 1 | 800 | Active | Felton |
| Bull Creek 2 | 531 | Active | Felton |

Typically, surface water diversions account for approximately half of SLVWD's supply. In above-average rainfall years, surface water diversions can potentially address 100% of demand. However, SLVWD only has enough surface water storage capacity to store a few days of diverted surface water. Thus, groundwater is still needed to augment surface supplies in fall and early winter months.

In addition to the surface water diversions on the North and Felton Systems, SLVWD also has an existing entitlement of 330 acre-feet per year to a portion of the yield from Loch Lomond Reservoir. The Reservoir is owned and operated by the City of Santa Cruz. SLVWD has not exercised their right to this water since the 1970s.

4.4 Distribution System Assets

The District's distribution system consists of 32 pressure zones, 144 miles of pipeline, 35 treated water tanks and reservoirs, and 28 booster pump stations. Pipeline sizes range from 2-inch to 14-inch in diameter, as shown in Table 4. Over half the distribution system pipelines are 4-inches in diameter or less. These restrictions have led to historic and on-going low water pressure issues.

Table 4. Distribution System Pipeline Inventory

| Pipeline Size (Inches) | Pipeline Length (Miles) |
|------------------------|-------------------------|
| 3 and under | 56.89 |
| 4 | 15.74 |
| 6 | 47.21 |
| 8 | 16.3 |
| 10 | 5.78 |
| 12 | 1.84 |
| 14 | 0.05 |
| TOTAL | 143.81 |

The District owns and maintains 35 tanks, comprised of various materials including redwood. Table 5 on the following page lists the District's tank inventory, and provides information on tank capacity, zone served, elevation, and location.

Table 5a. Storage Tank Inventory (North)

| System | Name | Capacity (Gallons) | Zone Served | Elevation (Feet) |
|-----------------|------------------------|---------------------|-----------------|------------------|
| North | Riverside Grove Tank | 380,000 | Riverside Grove | 1017 |
| | Blue Ridge Tank | 40,000 | Blue Ridge | 946.42 |
| | Reader Tank | 150,000 | Reader | 750 |
| | Alder Tank | 700 | Reader | Approx. 644 |
| | Lyon Reservoir | 3,000,000 | Lyon | 848.44 |
| | Little Lyon Reservoir | 250,000 | Lyon | 848 |
| | Eckley Tank | 4000 | Eckley | 1000 |
| | Blackstone Tank 1 | 22,000 | Blackstone | 797 |
| | Blackstone Tank 2 | 22,000 | Blackstone | 797 |
| | Big Steel Reservoir | 1,400,000 | Big Steel | 734.07 |
| | Huckleberry Tank | 125,000 | Huckleberry | 1021 |
| | Ralston Tank | 10,000 | Ralston | 950 |
| | Bear Creek Tank | 75,000 | Bear Creek | 760 |
| | Highland Reservoir | 60,000 | Highland | 900 |
| | Nina Reservoir 1 | 54,000 | Nina | 1200 |
| | Nina Reservoir 2 | 75,000 | Nina | 1200 |
| | Brookdale Reservoir | 721,000 | Brookdale | 575 |
| | Upper Swim Tank | 10,000 | Swim | 746.4 |
| | Lower Swim Tank | 9600 | Swim | 727.6 |
| | Spring Tank | 65,000 | Spring | 990 |
| | University Reservoir 1 | 50,800 | University | 826 |
| | University Reservoir 2 | 75,000 | University | 826 |
| | Reagan Reservoir | 14,500 | University | Approx. 808 |
| | Quail Tank 1 | 211,000 | Quail | 730 |
| | Quail Tank 2 | 240,000 | Quail | 730 |
| South Reservoir | 4 × 9000 | South | 1185 | |
| Echo Tanks | 100,000 | North Boulder Creek | 1060 | |

Table 5b. Storage Tank Inventory (South, Felton, and Mañana Woods)

| System | Name | Capacity (Gallons) | Zone Served | Elevation (Feet) |
|--------------|------------------------------|--------------------|-----------------|------------------|
| South | Probation Tank | 100,000 | Probation | 871.32 |
| | Lower Pasatiempo Reservoir | 100,000 | Upper Probation | 821.6 |
| | Upper Pasatiempo Reservoir | 100,000 | Upper Probation | 905.5 |
| Felton | Abandoned 1989 McCellan Tank | 4,500,000 | Pine | 544 |
| | McCloud Tank | 284,000 | McCloud | 515 |
| | Blair Tank | 255,000 | Blair | 500 |
| | Clearwell Tank | 250,000 | McCloud | 296.5 |
| | Felton Acres Tank | 100,000 | Pine | Approx. 474 |
| | Upper El Solyo Tank | 20,000 | El Solyo | 650 |
| | Pine Tanks | 18,000 | Pine | 641 |
| Mañana Woods | Blue Tank | 65,000 | Blue Zone | 731.33 |
| | Charlie Tank | 45,000 | Charlie Zone | 825.59 |

4.5 Wastewater System Assets

SLVWD provides wastewater collection and treatment for 56 parcels in a portion of Bear Creek Estates subdivision (units 3, 4, and 5). This area was first developed between 1963 and 1965 and expanded in 1975. Residential units were historically on private septic systems, and approximately half the units remained on private septic systems during the conversion to the sewer system. A private developer constructed the District's wastewater collection system and septic disposal system in 1985. The Wastewater System was acquired by SLVWD when the development requested annexation into the District's water system.

The existing wastewater treatment system consists of 1.2 miles of gravity sewers, an influent pump station with 2,600 linear feet of force main, a pneumatic lift station, and a two-stage trickling filter treatment system. SLVWD has a waste discharge permit to treat up to 12,000 gallons per day of wastewater, and then discharge it to a community leach field.

In 2005, SLVWD converted to a two-stage trickling filter for nitrogen removal to meet the Regional Water Quality Control Board requirements for 50 percent nitrogen removal prior to subsurface disposal. Later improvements included the following:

- 2009 – 3rd stage random pack media tank
- 2011 – Pumping modifications and internal recirculation/splitter ball valves
- 2013 – Air blowers and fine bubble diffusers to the clarifier tanks.

- In April 2016, the Central Coast RWQCB issued a Notice of Violation of the Waste Discharge permit to SLVWD for failing to meet the 50% removal requirement for nitrogen, excess flow violations for inflow and infiltration during rain events, and the provision for Operator training for Sewer/WWTP spills.

The District contracted with Infrastructure Engineering Corporation (IEC) to evaluate the collection and treatment systems and to develop recommendations for both systems. The IEC recommendations included Completion of smoke testing of remaining systems, installation of manhole inserts, epoxy sealing of manholes, and replacement of 195 LF of sewer pipeline. These recommendations have not been included in the District's current CIP.

4.6 Lompico Water System

The Lompico County Water District (LCWD) is a small system that was annexed by SLVWD in June 2016. The system serves 500 connections in the Lompico Creek canyon area. Raw water was formerly supplied by wells and surface water diversions from Mill Creek. Existing infrastructure consists of six redwood tanks, two water treatment plants, four wells, one pump station, and nine pressure-reducing valves. The system has three miles of water mains made of galvanized iron and PVC. Service laterals are in poor condition and are failing at a rate of three per month. Table 6 lists Lompico system infrastructure.

Table 6. Lompico County Water District Infrastructure

| Name | Capacity (gallons) | Material | Year Built | Elevation (feet) | Notes |
|----------------------------|--------------------|--------------|------------|------------------|---------------------|
| Kaski Tanks | 2 × 60,000 | Redwood | 1990 | 1265 | |
| Lewis Tank 1 | 100,000 | Redwood | | 1096 | |
| Lewis Tank 2 | 100,000 | Redwood | | 1330 | Appears demolished. |
| Lewis WTP | | | | 1090 | |
| Madrone Tanks | 2 × 60,000 | Redwood | 1990 | 1287 | |
| Well 1 | | | | 1026 | |
| Well 7A | | | | 1027 | |
| Well 5 | | | | 1099 | |
| Mill Creek WTP (Clearwell) | 48,000 | Bolted Steel | | 619 | |
| Madrone Pump Station | | | | 905 | |

As part of Lompico's annexation process, the following capital projects were identified and will be funded by an assessment to the Lompico customer:

1. Install 3 new Bolted Steel Tanks
2. Refurbish Mill Creek WTP
3. Replace Service Lines and Meters
4. Distribution System Interconnections
5. Install SCADA System at multiple sites
6. Replace existing Pressure Reducing Valve

The total cost of these projects was estimated at \$2,922,734. These costs are not included in the District's CIP since they will be funded through the assessment, however District staff will be responsible for managing the projects.

5.0 SUMMARY OF FINDINGS

Based on the information reviewed, this section summarizes findings for potential planning and capital improvement activities that would be beneficial in meeting the service objectives of the District's Strategic Plan. Further in this document, this list is compared to the District's current capital improvement program.

Recommendations are provided below for the following:

- Surface Water Supplies
- Treated Water Storage
- Water Distribution Facilities
- Groundwater Facilities
- Wastewater Facilities
- Lompico Water System

5.1 Surface Water

Surface water intakes and facilities include District raw water intakes and supply pipelines, surface water treatment plants, Loch Lomond supplemental surface water supply, and Lompico surface water supply.

Raw Water Intakes and Supply Pipelines

The existing raw water systems consist of several intakes along nine different creeks along Ben Lomond Mountain. Most of the raw water pipelines in these systems are above ground and exposed to the elements, vandalism, or other risks. District staff performed regular inspections on creek diversion structures. However, documentation is not available from these inspections to determine the extent of these assessments, or associated findings.

Future inspections should evaluate susceptibility to landslides, debris flows related to large stormwater flows, general condition, and structural integrity. The District should develop a standard checklist for creek diversion inspections, and document any known hydraulic restrictions or known material issues with the raw water pipelines. These assessments should also include a physical inventory of above-ground pipelines, and an evaluation of whether any of these lines should be buried or otherwise protected from vandalism and/or other risks.

Water Treatment Facilities

The District does not maintain a comprehensive planning document for its water treatment facilities and should consider completing a Water Supply and Treatment Master Plan for the two raw water treatment plants. The Water Treatment Master Plan would document all aspects of the treatment plant including treatment components (filtration, chemical addition, disinfection, etc.), treatment capacity, operational SOPs, maintenance practices, and component information (manufacturer, make/model, date installed, etc). The Master Plan would document current conditions, discuss known issues such as planned replacement or rehabilitation of treatment components, and identify potential future treatment challenges and improvements based on changes to raw water quality or changes in future regulations. This document would provide information valuable for developing a long-term CIP.

Loch Lomond Water Supply

In 2015, SLVWD established a strategic goal of developing the Loch Lomond water supply, including financial planning, completion of environmental review, and project design by 2020. The Loch Lomond Source Development Project, which was completed in 2010, recommended blending the water from Loch Lomond into the Felton Raw Water System prior to treatment at the Kirby Water Treatment Plant. This project remains critical to assure supply reliability during dry and critically dry years, especially if groundwater resources become restricted. Therefore, the project should be reviewed and the cost estimate brought up to 2016 values.

An option for groundwater recharge of Loch Lomond water may become available as part of the larger Santa Margarita Groundwater Basin Replenishment effort, following establishment of the Groundwater Sustainability Agency (GSA) that was discussed above. The GSA is being established to manage the shared groundwater resources to manage withdrawals and potentially establish a replenishment project. A project to recharge the Loch Lomond water supply could be partially funded through state or federal grants to help support the sustainable use of the groundwater basin.

Lompico Water Supply

Recent actions taken by the Regional Water Quality Control Board have prompted SLVWD to stop use of Lompico's surface water diversion and treatment system. SLVWD is currently providing water from the North System via a new pump station and intertie pipeline. It would be beneficial to review the Lompico supplies, to confirm that imported water is the most sustainable water supply option for the area. This study would include a review of potential sources of well and surface water contamination, and the measures needed to address these issues.

There has been discussion regarding the potential to divert storm water flows as a source for groundwater recharge, to improve groundwater supplies. This alternative would involve relocation and redesign of a surface water diversion on Lompico Creek to the Olympia quarry near Lompico Road as shown in Figure 6. A hydrogeologic investigation and a structural geology review of the quarry's current conditions would both be required.

Any review of water supply options should consider recent interest by the California Department of Fish and Wildlife in having the District provide dedicated surface water flows in Lompico Creek for Chinook salmon and steelhead recovery.

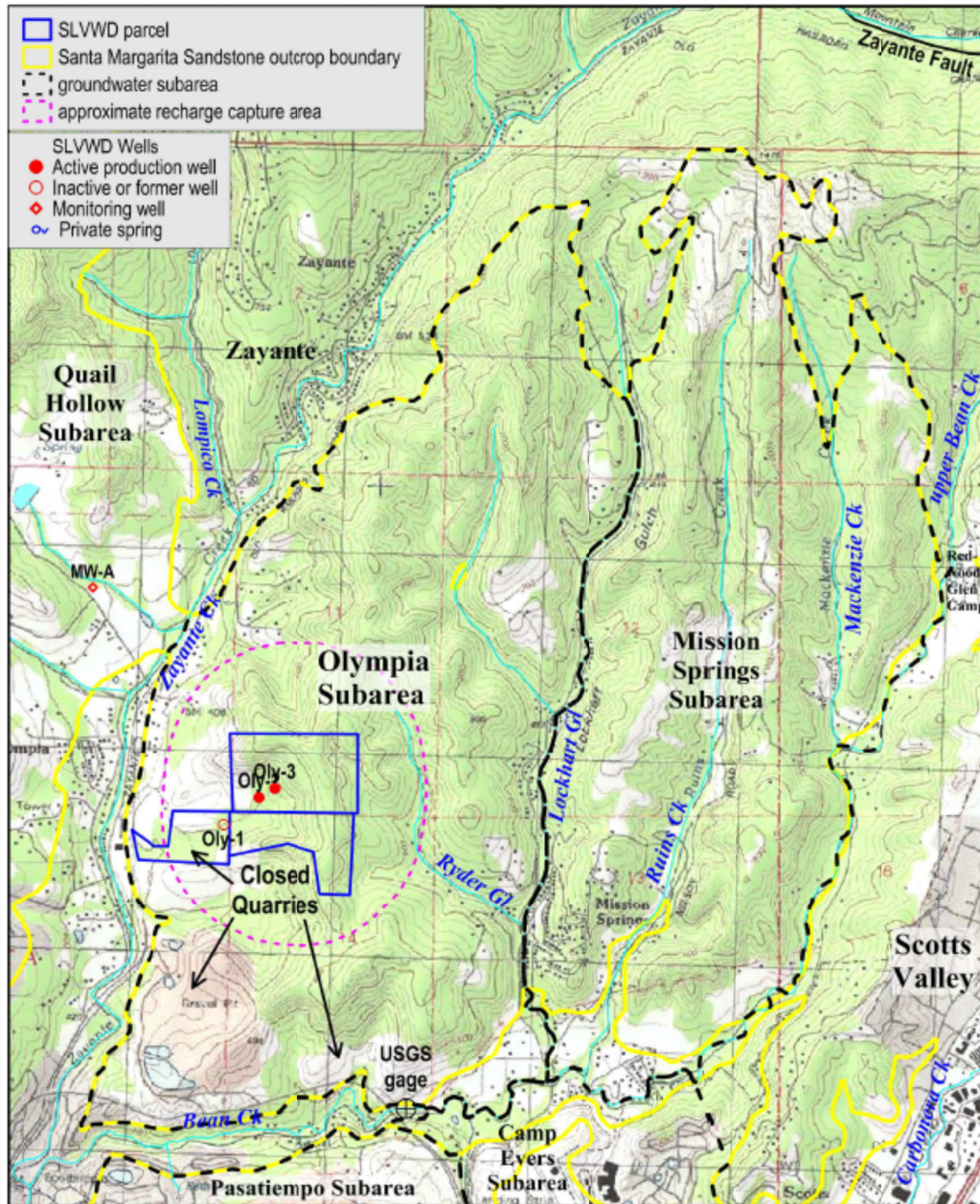

Figure 6. Potential Stormwater Surface Water Diversions at Currently Closed Quarries

5.2 Treated Water Storage

Tank inspections are performed regularly by SLVWD contractors and are scheduled to be performed again in the near future. Inspection reports from these inspections form the basis for an evaluation of tank condition including exterior coatings, liners, and roofs. District staff has developed a priority list for tank replacements, as listed in the current capital improvement program. However, additional review of the replacement needs using a risk-based analysis may be of use to the District. A risk-based methodology involves identifying which tanks and reservoirs have the highest likelihood failure and the greatest consequence of failure. These two factors form a numeric score and establish the priorities for rehabilitation or replacement. The risk-based analysis would also help to develop a timeline for

replacement or rehabilitation, in order to distribute tank replacements, which are usually a higher-cost capital replacement item, as appropriate over the long-term CIP.

Of special concern is seismic risk for the District's storage tanks, as determined by their proximity to the Zayante Fault, which runs through a large portion of Boulder Creek. At a minimum, Huckleberry Tank and Pump Station should be evaluated for seismic hardening, as pipeline connections between the building and the distribution system are of particular concern.

In addition to assessing condition, consideration should be given to the volume of available storage. Currently, the SLVWD has a shortfall in surface water storage. Water is pumped, diverted, and treated according to immediate demands. SLVWD should consider establishing a design standard for sizing new tanks to include:

1. A minimum storage volume for emergencies,
2. Fire storage volume and
3. Daily operational volume

Select storage tanks could be identified for enlargement during their planned replacement to meet increased storage needs.

5.3 Water Distribution Facilities

The District has 28 booster pump stations, and 144 miles linear assets (i.e., pipelines). Separate recommendations are provided for each category.

5.3.1 Booster Pump Stations

It is recommended that the District perform a physical assessment of each booster pump station, to identify deficiencies and document the current state of each facility. The assessment would use as its basis existing available documentation, including when each facility was put into service and if any part of the facility has been upgraded. The current documentation would be expanded to include assessments of the mechanical equipment, structural issues, ventilation, entrance/security, safety issues, electrical, and communication systems.

Following the physical assessment, identification of needs, and associated cost estimates, the recommended improvements would then be grouped and prioritized to most effectively minimize risks, and then either added to the long-term CIP, or included on a maintenance priority list as appropriate. If booster stations are known to be failing or are critical to the District, these facilities should be assessed first.

5.3.2 Linear Assets

The District owns and maintains approximately 144 miles of distribution pipeline. A portion of this system, a single pipeline located within the State Highway 9 in the Boulder Creek area, forms the backbone distribution pipeline for the North System distribution network. More specifically, the San Lorenzo Park, Ramona Woods, San Lorenzo Woods, and Blue Ridge zones are all served by a single supply pipeline within Highway 9, and have redwood tanks as their only storage source. Due to this configuration, these areas are particularly vulnerable to a loss of service during or after a natural disaster. In addition, areas of known landslide risk and the area between Two Bar Road and Bear Creek Road within the Zayante Fault Zone are of considerable concern.

VWHA recommends that the District develop a risk-based linear asset model to evaluate and prioritize recommendations for pipeline rehabilitation and replacement. The model would overlay parameters that determine Likelihood of Failure, and parameters that measure Consequence of Failure, to assign a risk score to every pipeline asset.

A risk-based linear asset management program will also serve to consolidate the large volume of available data, both written and known by field staff, that is available regarding the District's linear assets. Some of the benefits that would be provided by this approach include the following:

- A linear asset management program would include all available information on pipeline condition, leaks, fire flow, O&M issues, soil conditions, seismic risk, landslide risk, etc.
- The model can be customized to SLVWD's needs including fire risk, landslides, loss of water pressure and security.
- The model would utilize available GIS data to determine nearby critical facilities such as fire stations, clinics, and hospitals, major roadway intersections, etc.
- A numerical model allows for staff to focus on the assets that present the highest risk, as measured by a combination of likelihood and consequence of failure.
- Understanding and planning for long-term risk will help to smooth out the year-to-year costs of pipeline replacements.

5.4 Groundwater Facilities

Scotts Valley Water District (SVWD) and SLVWD share the same groundwater basin. As water usage increases over time (presuming continued development of the combined area), effective sharing of resources must be considered in managing groundwater use, as groundwater overdraft is a potential risk if the two agencies do not develop a plan to manage use. More specifically, SVWD's operations may result in an unacceptable level of drawdown to the regional groundwater table, which may directly impact SLVWD's ability to pump from the same aquifer.

This drawdown is shown in Figure 5-29 of the Urban Water Management Plan, which documents a 160-foot drop in groundwater levels in the Pasatiempo Wellfield and Mañana Woods well since 1985.

SVWD and SLVWD, along with other local agencies, are discussing the possibility of establishing a Groundwater Sustainability Agency (GSA). One of the collective objectives of this agency is to develop a plan to stabilize groundwater levels and recharge some or all of the lost volume.

In addition to addressing the public groundwater facilities, a 2001 study of private well production yielded an estimate of less than 100 acre-feet per year. This estimate should be revisited, and it is recommended that the District develop a database of private wells, considering the significant reliance that SLVWD and SVWD have on groundwater, as well as recent legislation that could affect groundwater basin management.

5.5 Wastewater Facilities

IEC engineers conducted an assessment of the Bear Creek estates wastewater collection and treatment system in response to recent action by the Central Coast RWQCB. Following this assessment, IEC developed the following recommendations to address inflow and infiltration:

1. Inspect air bubble diffusers and configuration in clarifier tanks
2. Verify blowers are adequately sized

3. Install chemical feed system to provide additional alkalinity
4. Clean and Inspect tank for cracks
5. Conduct Field Test of Trickling Filter 1 and Clarifier No. 3
6. Maintain CO level in Clarifier No. 3 and add alkalinity as required
7. Complete smoke testing of remaining private laterals
8. Install manhole inserts
9. Epoxy-seal manholes
10. Replace 195 LF of sewer pipeline

IEC estimated the collection system improvements to be \$84,000. IEC did not provide a cost for wastewater treatment facility improvements. IEC also developed an Emergency Spill Response Plan for the wastewater treatment plant that would bring SLVWD back into compliance with their waste discharge permit.

To assist in long-term collection system management and to meet the requirements of the Statewide WDR, the District should also develop a Sewer System Management Plan for the Bear Creek Treatment System in parallel with the proposed capital improvements.

5.6 Lompico Water System

Water quality in the Lompico area has been adversely affected by septic system leaks and high levels of iron and manganese. The recently renovated Lewis Water Treatment Plant can treat groundwater from the Lewis Wellfield off West Drive, though the wellfield remains on standby. The Mill Creek Water Treatment Plant also remains on standby, and may require upgrades to meet State water quality standards. Treated water is currently supplied to Lompico through an intertie with SLVWD.

Potential infrastructure upgrades may include tank consolidation, wellhead repair, SCADA and automation system implements, and pump station installations. Challenging topography and narrow streets will likely increase the costs of improving Lompico's infrastructure.

6.0 RECOMMENDATIONS FOR DEVELOPMENT

This section summarizes findings and recommendations from the Capital Asset Cost of Service Study.

6.1 Review of Current CIP

The District provided a Capital Improvement Planning document that included known critical projects such as replacement of a number of redwood tanks and the completion of system interties. The District has also prepared a Capital Improvement Plan for the Lompico Water System as part of the annexation process. These two CIP documents were developed based on historical lists of needed repairs and replacements, filtered using institutional knowledge. The District's CIP included estimated project costs and priorities, but no implementation timeline.

The District's historical CIP strategy has been to fund projects through a pay-as-you-go approach. This strategy has resulted in the funding of many small and medium sized capital projects. However, The District has significant capital assets that are approaching the end of their expected life. The current strategy does not allow for a temporary, increased level of spending that will be required in the future to address more significant infrastructure improvements.

Based on discussions held with District staff regarding the Agency's most critical needs, the first three years of the District's current CIP should be implemented. Recommended projects, priorities, and costs assigned by District staff are listed in Table 7. The District received confirmation through an outside peer review that the assigned costs are appropriate.

In order to accurately project projects and costs beyond this timeframe, it is recommended that the District complete additional system-wide master planning. The most important planning activity to pursue in the next three years would be the implementation of an asset management approach for pipeline, storage, and pumping plant asset rehabilitation and replacement.

Table 7. Three-Year CIP

| Project/Category | District Priority (See Note 1) | Estimated Cost (\$) | Cost Per Fiscal Year (2016 Dollars) | | | |
|--------------------------------------|-----------------------------------|------------------------|-------------------------------------|------------------|------------------|------------------|
| | | | 16/17 | 17/18 | 18/19 | 19/20 |
| Water Supply - Sources | | | | | | |
| Fall Creek Diversion | 90 | 800,000 | 800,000 | | | |
| Olympia Groundwater Well | 87 | 1,500,000 | | 1,500,000 | | |
| Water Supply - Distribution | | | | | | |
| Lyon Zone Water | 155 | 450,000 | 450,000 | | | |
| Bull Spring Main | 127 | 750,000 | 750,000 | | | |
| Hihn Road Main | 116 | 90,000 | | 90,000 | | |
| Worth Lane Main | 101 | 120,000 | | | 120,000 | |
| Sequoia Avenue Main | 98 | 120,000 | | | 120,000 | |
| Fairview Booster PS | 95 | 200,000 | | | 200,000 | |
| Felton Acres Tank and PS | 92 | 300,000 | | | 300,000 | |
| Hillside Dr Main | 92 | 240,000 | | | | 240,000 |
| Riverview Drive Main | 92 | 240,000 | | | | 240,000 |
| Blue Ridge Drive Main | 89 | 300,000 | | | | 300,000 |
| Brackney Road Main | 89 | 225,000 | | | | 225,000 |
| Buena Vista Main | 89 | 180,000 | | | | 180,000 |
| Water Supply - Storage | | | | | | |
| Highland Water Storage Tank | 91 | 225,000 | 225,000 | | | |
| Echo Water Storage Tanks | 88 | 500,000 | | 500,000 | | |
| El Solyo Water Storage Tank | 88 | 300,000 | | 300,000 | | |
| Felton Heights Water Storage Tank | 86 | 150,000 | | | 150,000 | |
| Mañana Woods Blue Water Storage Tank | 85 | 200,000 | | | 200,000 | |
| Bear Creek Estates | 76 | 125,000 | | | 125,000 | |
| Blue Ridge Storage Tank | 76 | 150,000 | | | | 150,000 |
| Brookdale Storage Tank | 73 | 350,000 | | | | 350,000 |
| Water Supply - Production | | | | | | |
| Bennett Intake Transmission Line | 114 | 495,000 | 495,000 | | | |
| Quail Hollow Groundwater Well | 99 | 1,000,000 | | | 1,000,000 | |
| Bennett Booster PS | 94 | 390,000 | | | 390,000 | |
| Water Supply - Treatment | | | | | | |
| Lyon Water Treatment Plant SCADA | 105 | 150,000 | 150,000 | | | |
| TOTAL | | 9,550,000 | 2,870,000 | 2,390,000 | 2,605,000 | 1,685,000 |

Notes:

1. A higher number denotes a higher priority project.

In order to estimate costs beyond the 3-year timeframe, VWHA prepared a concept level projection of overall system value, based on available information, and also developed a possible distribution of replacement costs for each asset class.

6.2 Conceptual Long-Term Asset Valuation

Table 8 lists the District's asset classes, associated value by asset class, and projected replacement cost in current dollars. The process used to develop the asset costs and cost distribution is shown in Figure 8:

Figure 8. Asset Valuation Approach



Table 8. SLVWD Capital Asset Replacement Cost Estimate

| Asset ^{Note 1} | Cost Per Unit ^{Note 2} | Asset Quantity | Unit | Useful Life (Years) ^{Note 2} | Total Asset Replacement Cost (\$) ^{Note 3} | Total Cost to Replace by 2026 | Cost Per Year (2016-2025) | Total Cost to Replace by 2050 | Cost Per Year (2026-2050) | Total Cost to Replace by 2070 | Cost Per Year (2051-2070) |
|---------------------------------------|---------------------------------|----------------|-------------|---------------------------------------|---|-------------------------------|---------------------------|-------------------------------|---------------------------|-------------------------------|---------------------------|
| Pipes (20-60-20) | \$70 | 760,320 | Linear foot | 70-100 | \$53,222,400 | \$10,644,480 | \$1,064,448 | \$31,933,440 | \$1,277,338 | \$10,644,480 | \$532,224 |
| Tanks (20-60-20) | \$3 | 9,240,000 | Gallon | 50-70 | \$27,720,000 | \$5,544,000 | \$554,400 | \$16,632,000 | \$665,280 | \$5,544,000 | \$277,200 |
| Pump Stations (20-60-20) | \$1,000,000 | 31 | Each | 20-30 | \$31,000,000 | \$6,200,000 | \$620,000 | \$18,600,000 | \$744,000 | \$6,200,000 | \$310,000 |
| Wells (10-60-30) | \$1,500,000 | 10 | Each | 20 | \$15,000,000 | \$1,500,000 | \$150,000 | \$9,000,000 | \$360,000 | \$4,500,000 | \$225,000 |
| Treatment (0-60-40) | \$2.50 | 2,360,480 | Gallon | 25 | \$5,901,200 | \$0 | \$0 | \$3,540,720 | \$141,629 | \$2,360,480 | \$118,024 |
| Diversions (10-60-30) | \$375,000 | 10 | Each | 50 | \$3,750,000 | \$375,000 | \$37,500 | \$2,250,000 | \$90,000 | \$1,125,000 | \$56,250 |
| Admin/Operations Buildings (10-60-30) | \$112.44 | 3 | Square-foot | 60 | \$8,147,604 | \$814,760 | \$81,476 | \$4,888,562 | \$195,542 | \$2,444,281 | \$122,214 |
| TOTAL (\$) | | | | | \$144,741,204 | \$25,078,240 | \$2,507,824 | \$86,844,722 | \$3,473,789 | \$32,818,241 | \$1,640,912 |

Notes:

1. Numbers in parentheses designate the percentage of each asset group that is planned for replacement by 2025, from 2026-2050, and from 2051-2070. Replacement percentages are
2. Unit costs are assigned in current dollars, using industry standard average costs for similar installations. Actual costs may vary depending on individual facility replacement needs and
3. Additional assumptions regarding asset useful life and unit costs, including how information was developed to estimate current age and replacement unit costs, are included in Section XX of
4. The tank asset quantity includes a 10% volume contingency to account for replacement of small tanks with larger tanks.

This page left intentionally blank

Table 8 lists the percentage of each asset that is expected to be replaced in each of the three replacement divisions in parentheses in the “Asset” column. For example, “20-60-20” means 20% of the asset replacement cost is assigned to the first time period (2016-2025), 60% of the total cost is assigned to the second time period (2026-2050), and 20% of the cost is assigned to the third time period (2051-2070). The distribution of cost was estimated for each asset class based on average age, expected useful life, and assumed condition. Using this approach, the District should expect to spend approximately \$2.5 million annually during the next ten years, and approximately \$3.5 million annually for the following 20 years, in order to replace assets based on service life.

The time periods and associated asset replacement percentages from Table 8 are also shown graphically in Figure 9. The three bars represent each asset replacement period. The bar height corresponds to the total annual asset replacement cost within the time period. Each bar is subdivided into asset classes, with each color representing the annual asset class replacement cost.

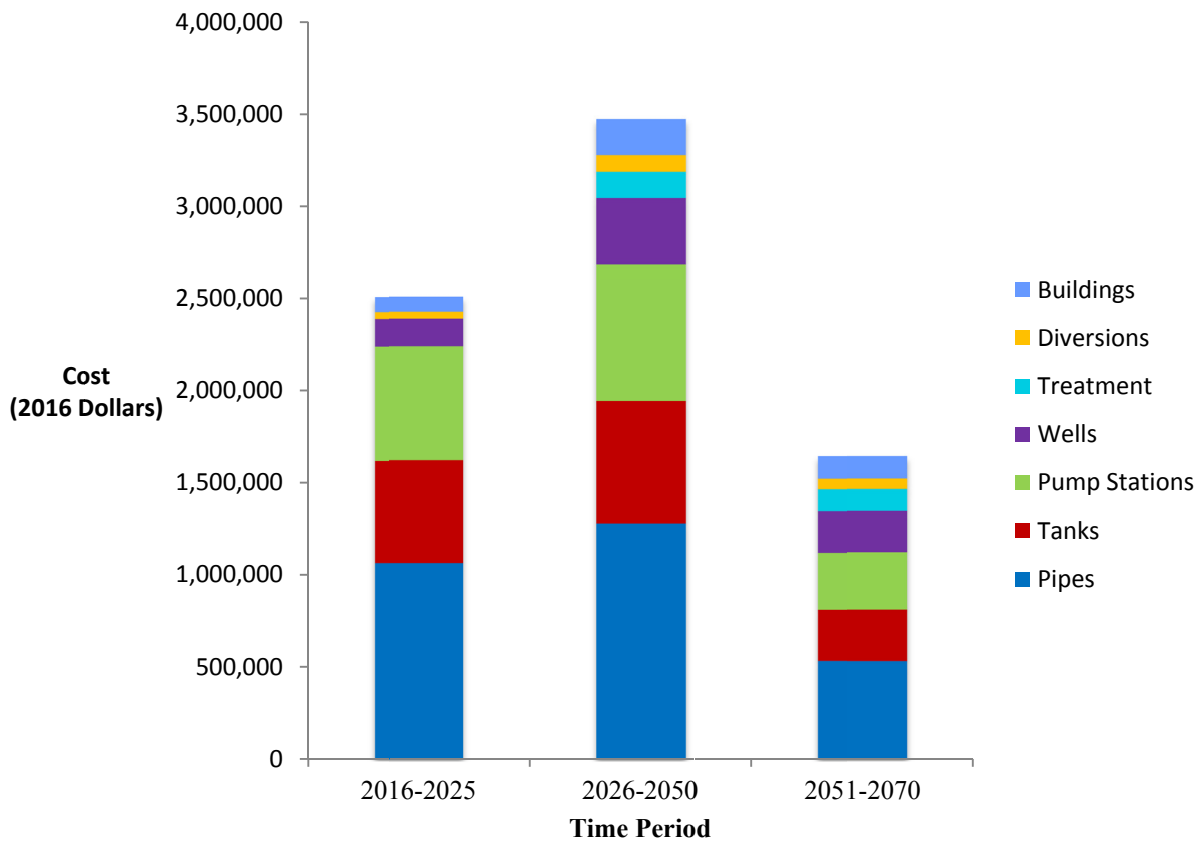

Figure 9. Estimated Annual Costs per Future Time Period